

SECTION A-A

PARTS LIST			
ITEM	QTY	PART NUMBER	DESCRIPTION
1	1	41143U01	PMB 4 PRODUCT 4" PASS THRU TOWER
3	1	MBB58-E ADA	LOW PROFILE BACK BAR UNIT, 58", BLACK FINISH
4	1	DP-820D-30	SM_DR TRAY MATRIX

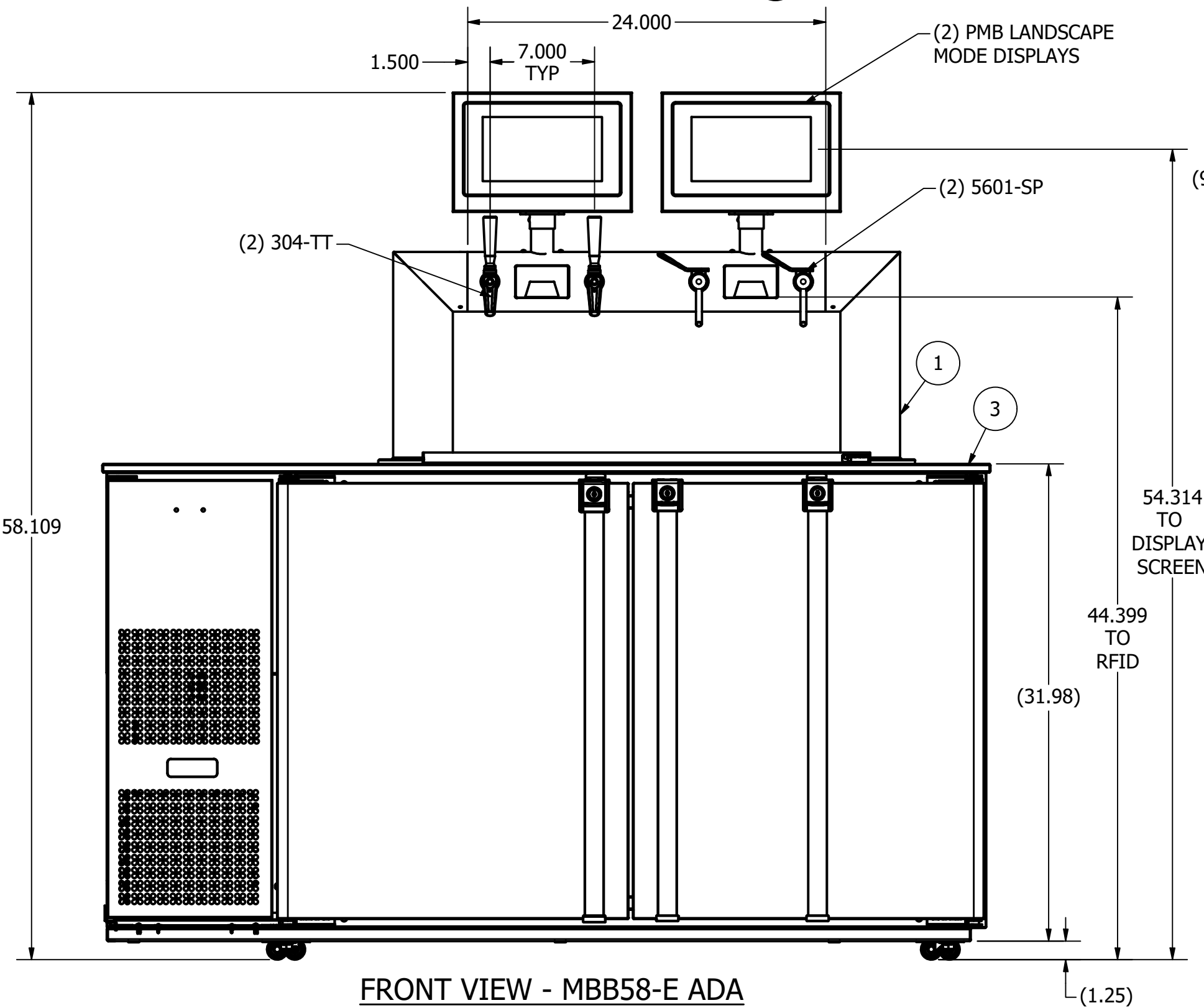

FRONT VIEW - MBB58-E ADA

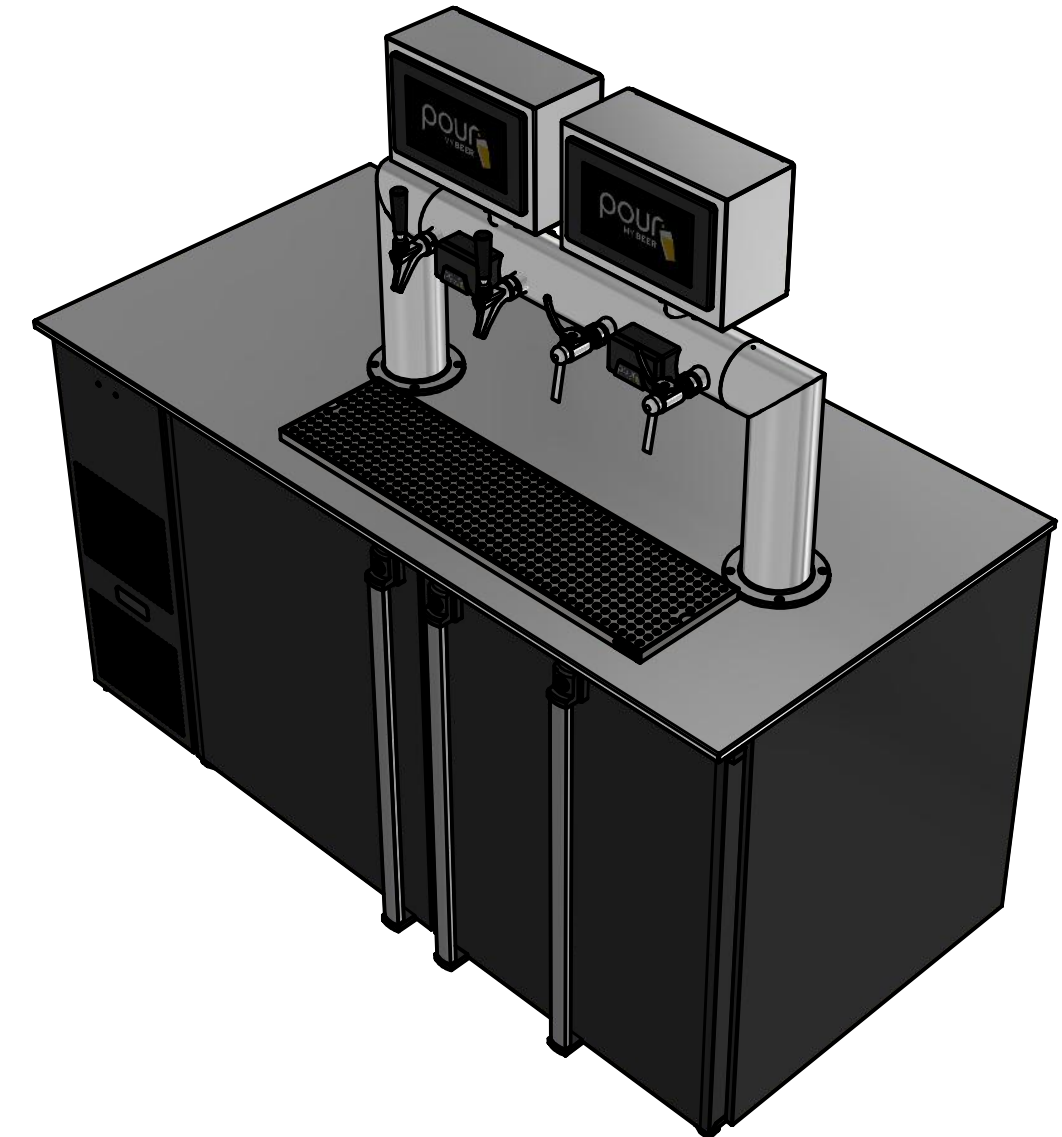
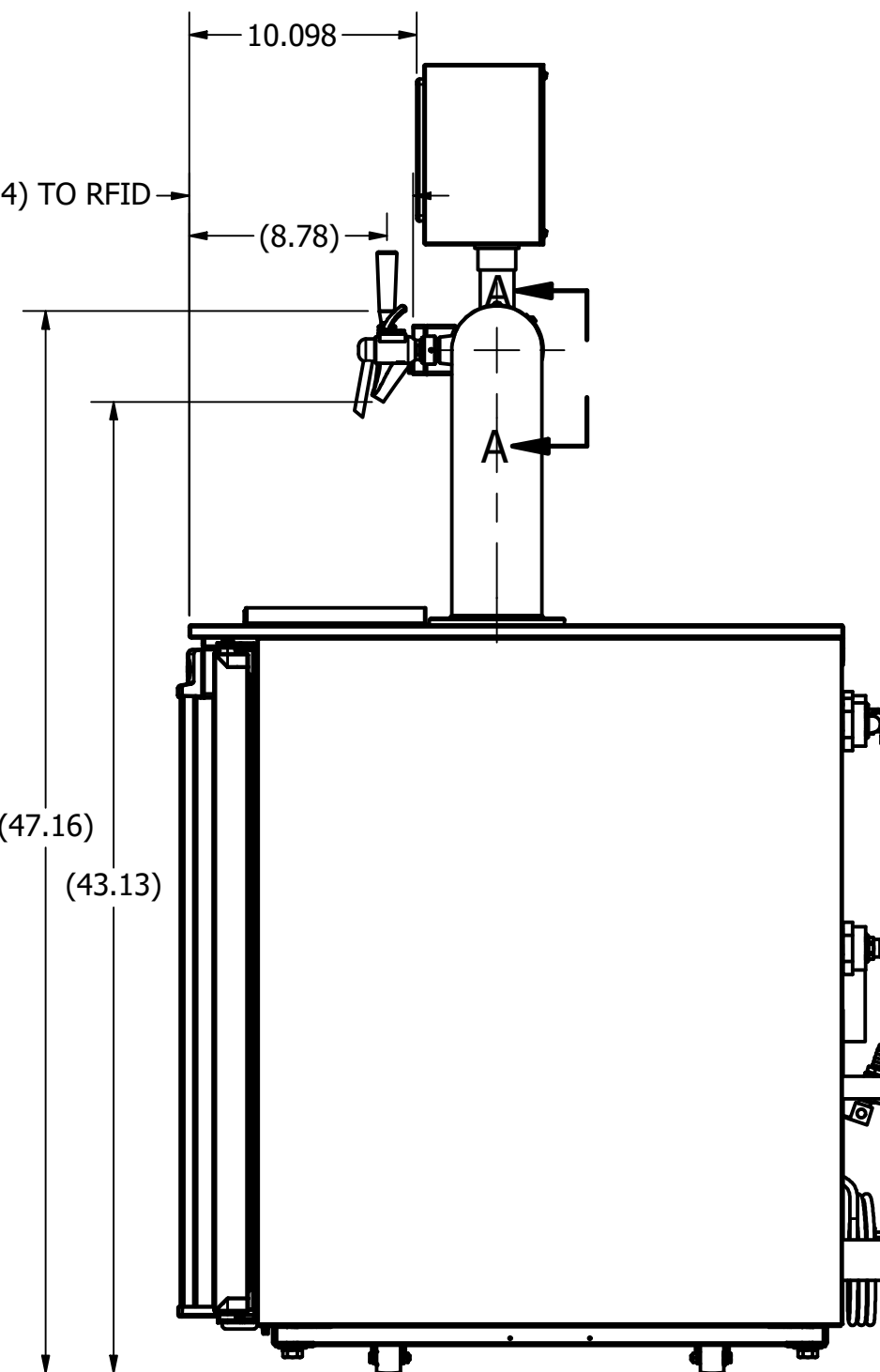

COMES WITH CO2 GAS REGULATOR AND 4 X "D" COUPLERS.

WHAT IS NOT PROVIDED: THE CO2 GAS AND THE ACTUAL BEER

**REQUIREMENTS**

**NETWORKING REQUIREMENTS:**

1. HARD-LINE INTERNET CONNECTION TO THE POUR MY BEER SERVER COMPUTER. (x1).
2. HARD-LINE ETHERNET CONNECTION FROM THE POUR MY BEER SERVER COMPUTER TO THE MOBILE UNIT. (x1).
3. HARD-LINE ETHERNET CONNECTION FROM THE POUR MY BEER CHECK-IN TERMINAL(S) (x1 FOR EACH TERMINAL).

ALL LINES SHOULD BE TESTED AND TERMINATED BY THE CUSTOMER. THE POURMYBEER TERMINAL WILL SIT NEXT TO YOUR POS TERMINAL (THE POURMYBEER SYSTEM DOES NOT PROCESS PAYMENT). IF YOU WOULD LIKE MORE THAN ONE CHECK-IN AREA YOU WILL NEED ANOTHER LINE TO RUN TO THAT LOCATION.

GAS REQUIREMENTS: YOU WILL NEED TO PROVIDE YOUR OWN CO2 GAS TO CONNECT TO THE REGULATOR

SERVICE REQUIREMENTS: DRAFT TECH IS REQUIRED TO SERVICE AND CLEAN THE MOBILE UNIT ONCE A MONTH LIKE A REGULAR SYSTEM.

- POWER REQUIREMENTS:
- 115V, 1 PHASE, 60 HZ
  - FULL LOAD AMPS - 12.2 AMPS
  - DEDICATED 15 AMP CIRCUIT

PLUG TYPE: NEMA-5-15P  
CORD LENGTH: 8'

DRAIN:  
DRAIN TO BOTTLE IN FRIDGE

GENERAL TOLERANCES UNLESS OTHERWISE SPECIFIED		MATERIAL		MICRO MATIC	
DEC. PL.	INCHES	MM	SPECIFICATION	EST. WT.	
XX	±0.1	±2.5		N/A	
X.XX	±0.01	±0.25			
X.XXX	±0.005	±0.125			
SURFACE FINISH	✓	✓	DESCRIPTION		SHEET 1 OF 2   SCALE 1 : 8   SIZE C
ANGLES ±1°			PMB 4 PRODUCT ADA 58"		ITEM NO. /TYPE/REV.
BREAK ALL SHARP EDGES			DISPENSER		41142U01.dwg

EIN/CRM	REV	RELEASED DESCRIPTION	DATE	ENG	APPD
	00		06/15/2021	NJS	

MBB-58-E ADA  
KEG FOOTPRINTS

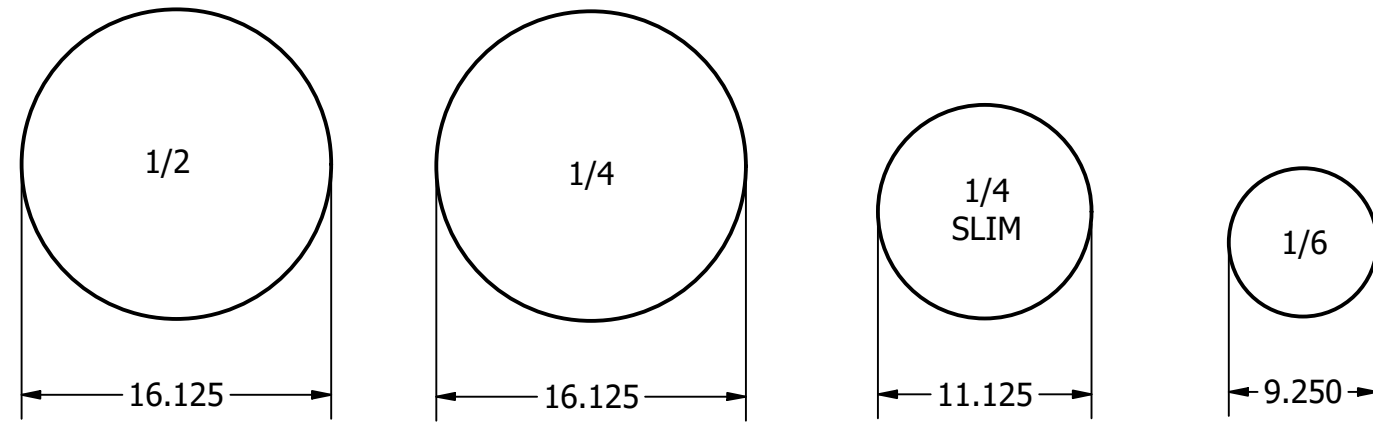

COOLING SYSTEM BOTTLE  
FRIDGE ZONE WALL  
DRAIN BOTTLE

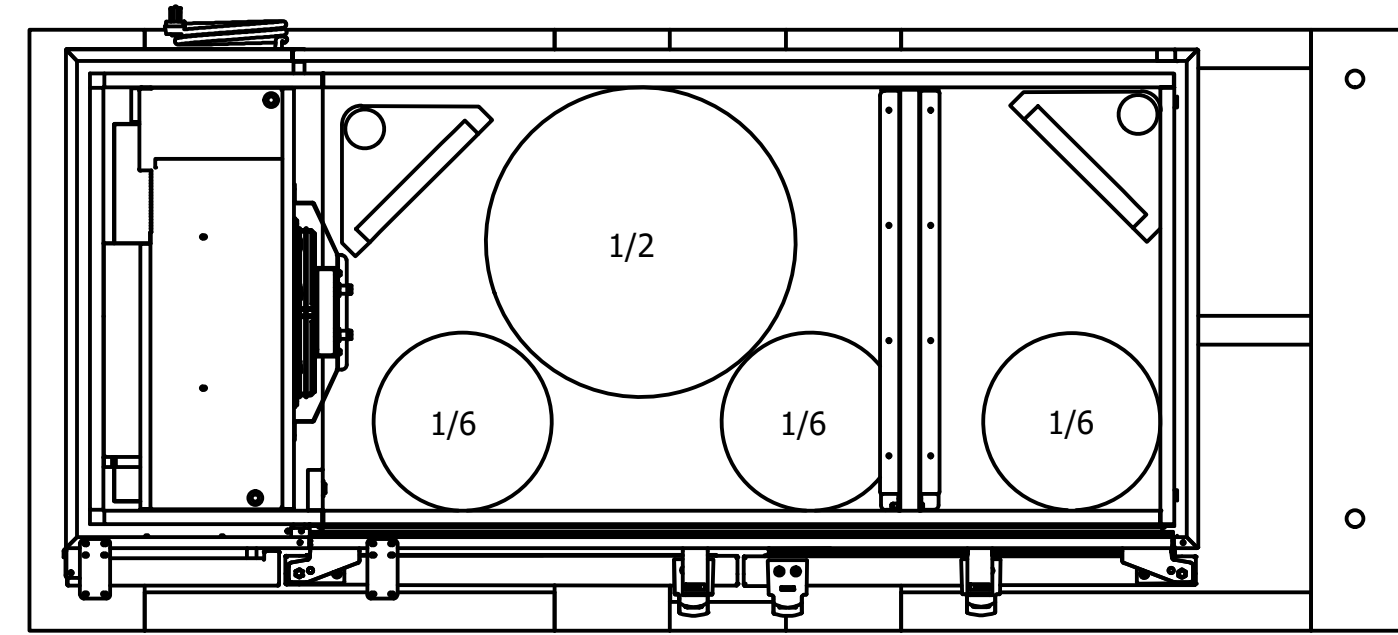
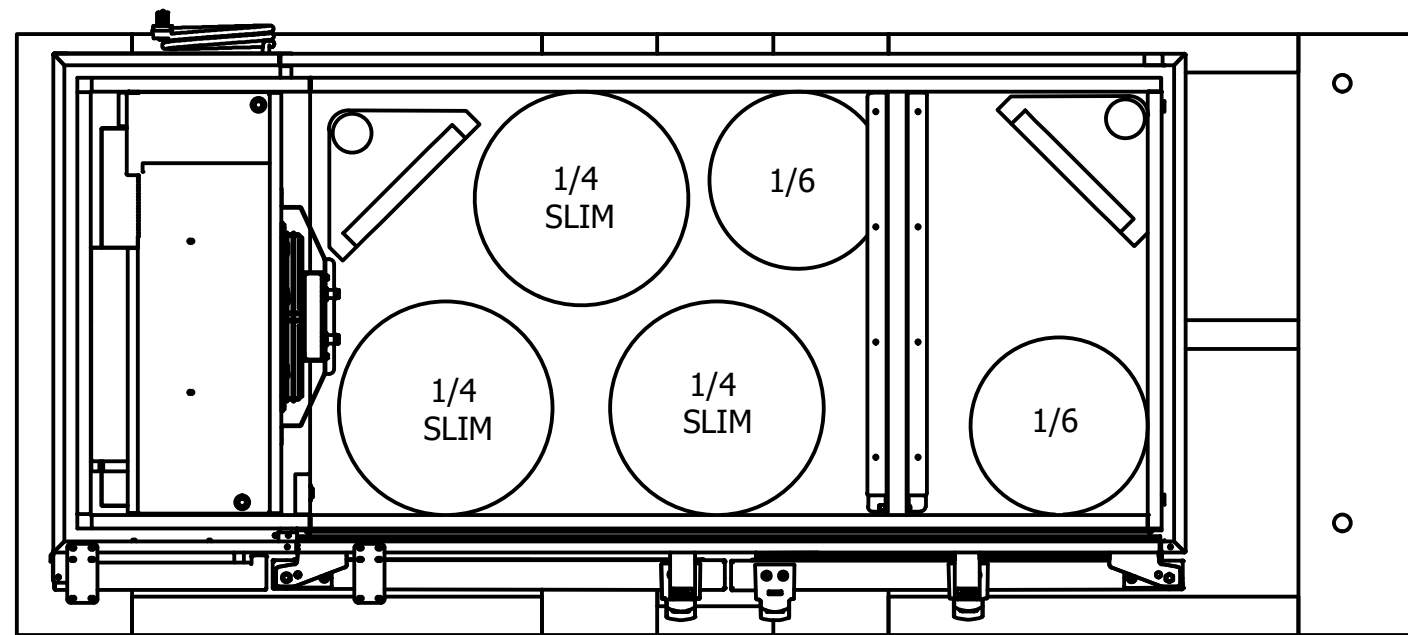
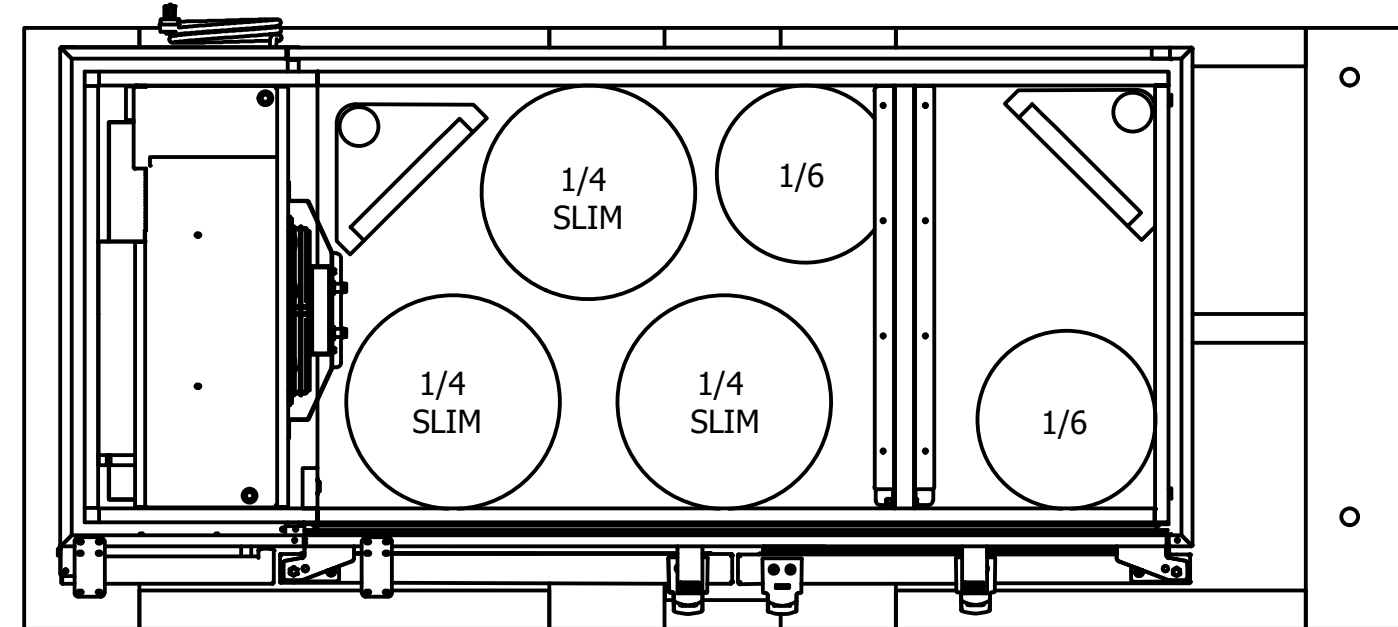
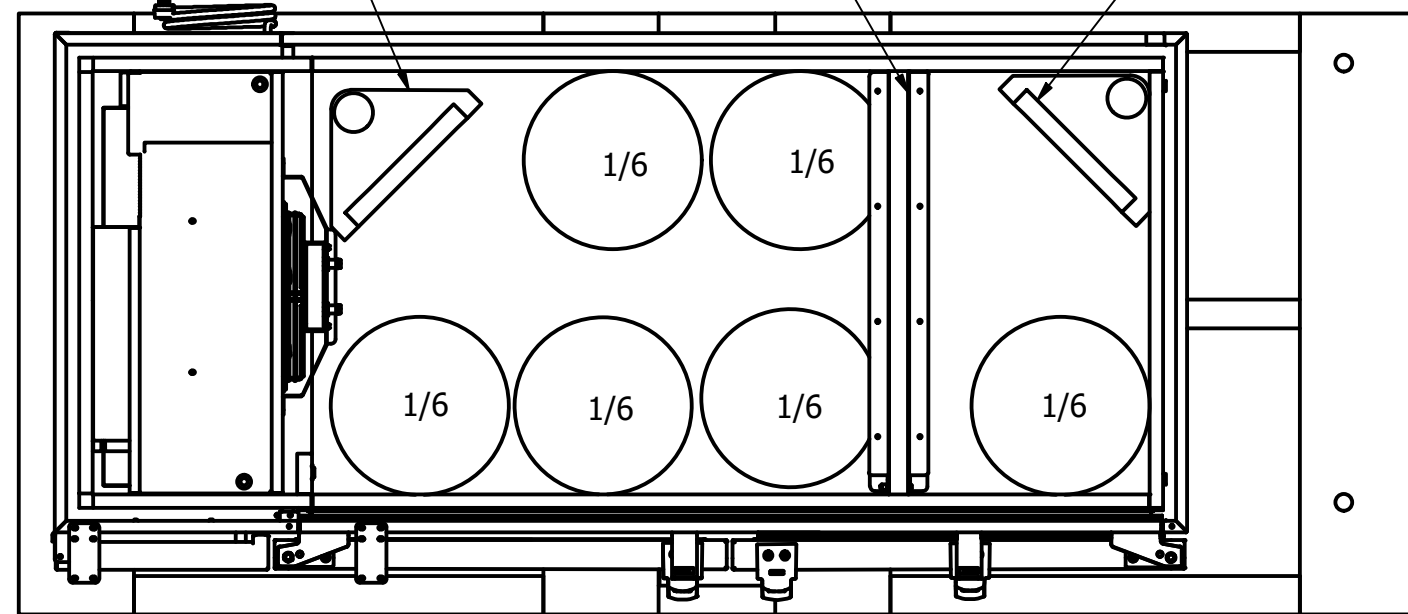

GENERAL TOLERANCES UNLESS OTHERWISE SPECIFIED DEC. PL. INCHES MM XX ±0.1 ±2.5 X.XX ±0.01 ±0.25 X.XXX ±0.005 ±0.125 SURFACE FINISH ANGLER ±1° BREAK ALL SHARP EDGES		MATERIAL Generic SPECIFICATION EST. WT. N/A DESCRIPTION	
SHEET 2 OF 2 ITEM NO. /TYPE/REV.		SCALE 1 / 10 SIZE C	41142U01.dwg