

PARTS LIST				
ITEM	QTY	PART NUMBER	DESCRIPTION	
1	1	40997U01	PMB 6 PRODUCT 4" PASS THRU TOWER	
3	1	MBB68-E-ADA-HC_PMB	LOW PROFILE BACK BAR UNIT, 68", BLACK FINISH	
10	1	DP-820D-45	SM_DR TRAY MATRIX	

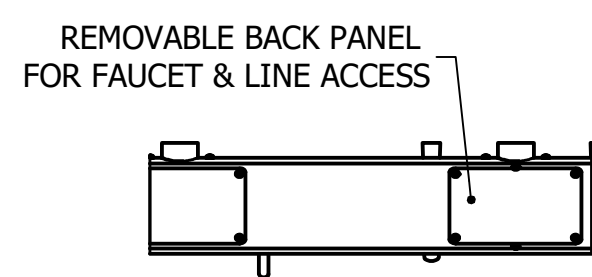

SECTION A-A

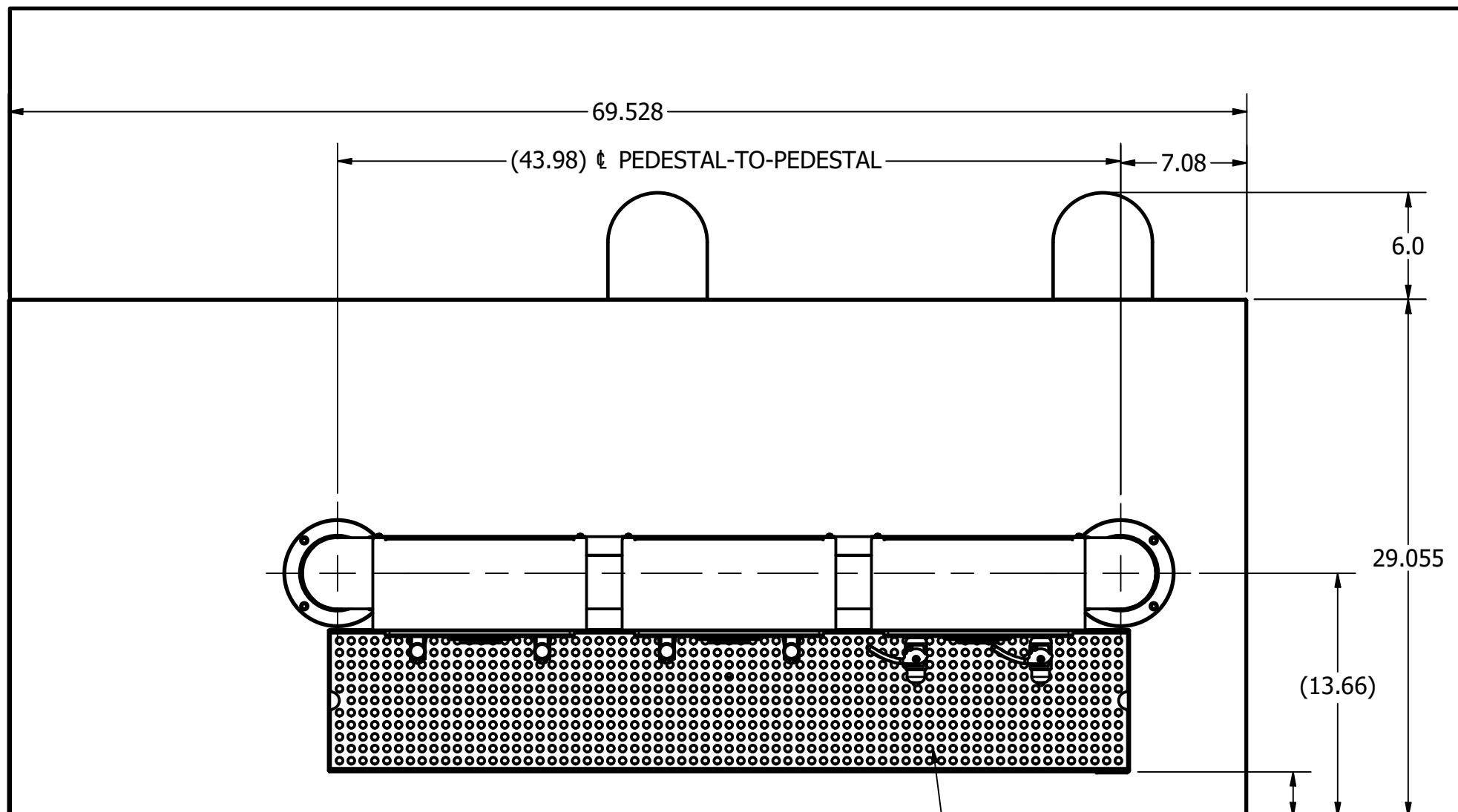
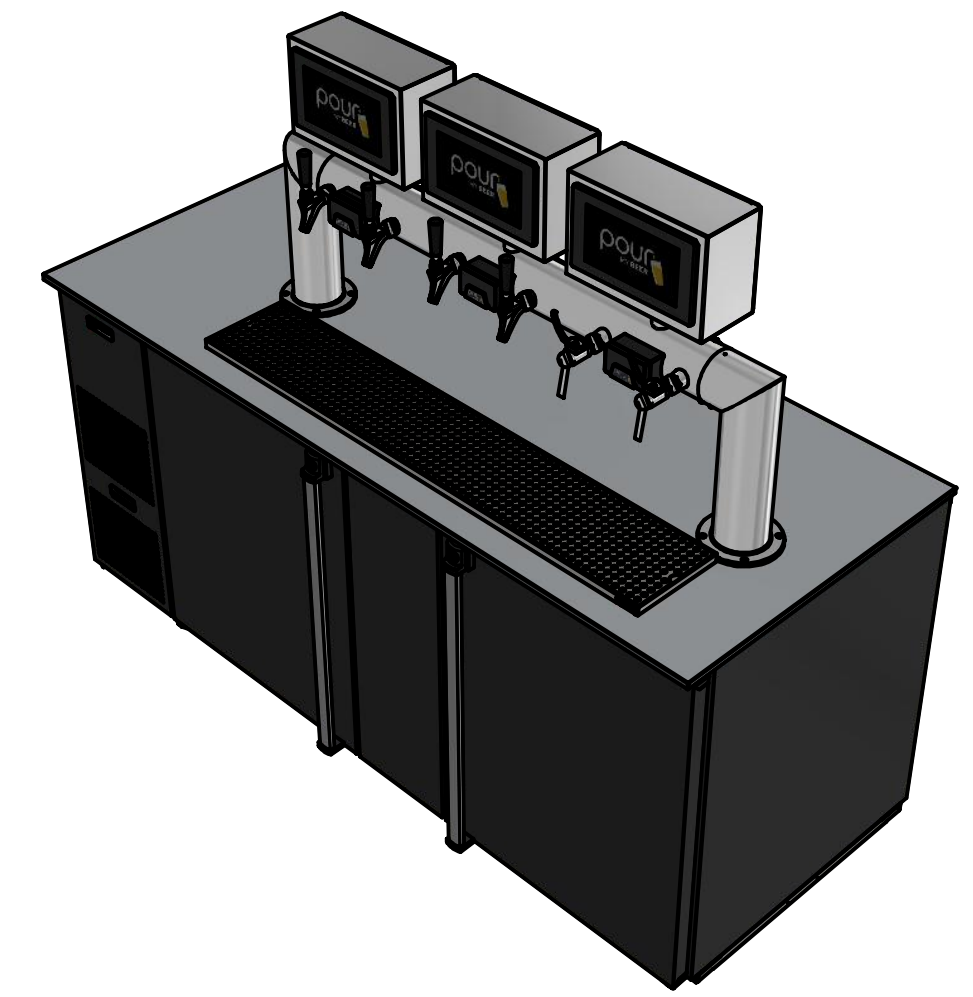

COMES WITH CO2 GAS REGULATOR AND 6 X "D" COUPLERS.
WHAT IS NOT PROVIDED: THE CO2 GAS AND THE ACTUAL BEER

- REQUIREMENTS**
NETWORKING REQUIREMENTS:
1. HARD-LINE INTERNET CONNECTION TO THE POUR MY BEER SERVER COMPUTER. (x1).
 2. HARD-LINE ETHERNET CONNECTION FROM THE POUR MY BEER SERVER COMPUTER TO THE MOBILE UNIT. (x1).
 3. HARD-LINE ETHERNET CONNECTION FROM THE POUR MY BEER CHECK-IN TERMINAL(S) (x1 FOR EACH TERMINAL).

ALL LINES SHOULD BE TESTED AND TERMINATED BY THE CUSTOMER. THE POURMYBEER TERMINAL WILL SIT NEXT TO YOUR POS TERMINAL (THE POURMYBEER SYSTEM DOES NOT PROCESS PAYMENT). IF YOU WOULD LIKE MORE THAN ONE CHECK-IN AREA YOU WILL NEED ANOTHER LINE TO RUN TO THAT LOCATION.

GAS REQUIREMENTS: YOU WILL NEED TO PROVIDE YOUR OWN CO2 GAS TO CONNECT TO THE REGULATOR

SERVICE REQUIREMENTS: DRAFT TECH IS REQUIRED TO SERVICE AND CLEAN THE MOBILE UNIT ONCE A MONTH LIKE A REGULAR SYSTEM.

- POWER REQUIREMENTS:
- 115V, 1 PHASE, 60 HZ
 - FULL LOAD AMPS - 12.2 AMPS
 - DEDICATED 15 AMP CIRCUIT

PLUG TYPE: NEMA-5-15P
CORD LENGTH: 8'

DRAIN:
DRAIN TO BOTTLE IN FRIDGE

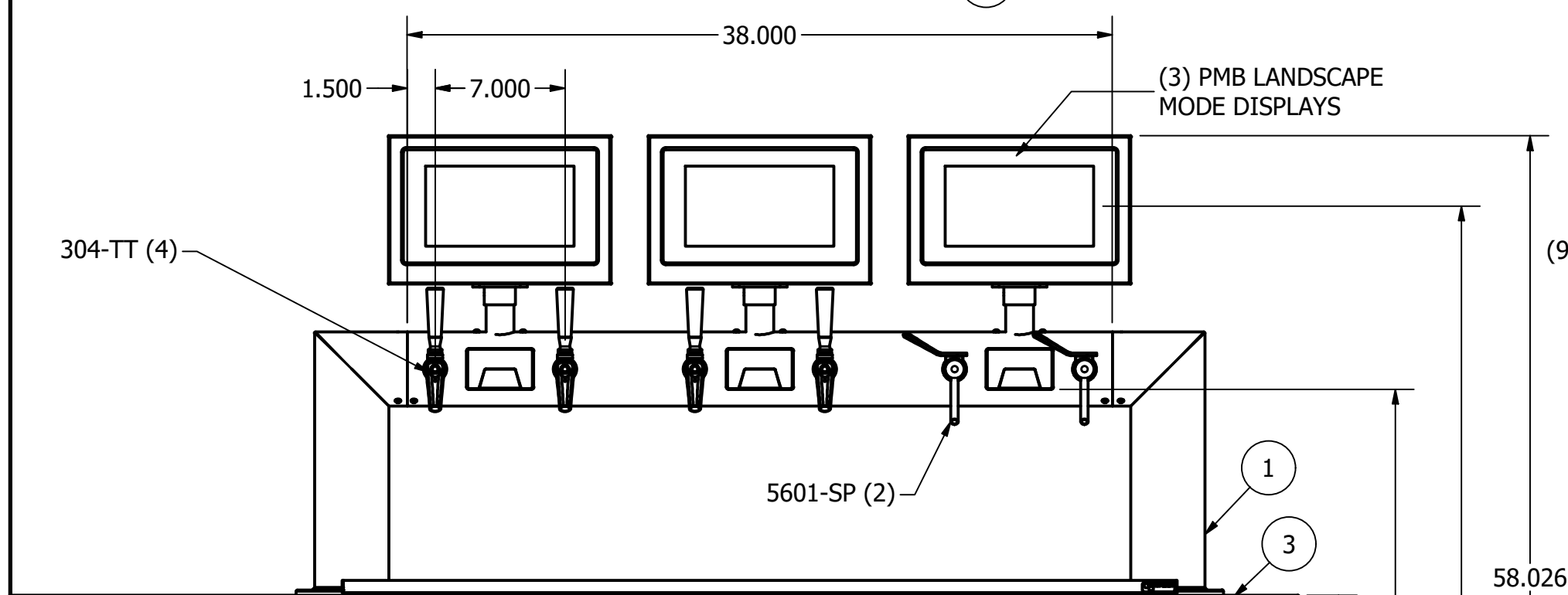

FRONT VIEW - MBB68-E ADA

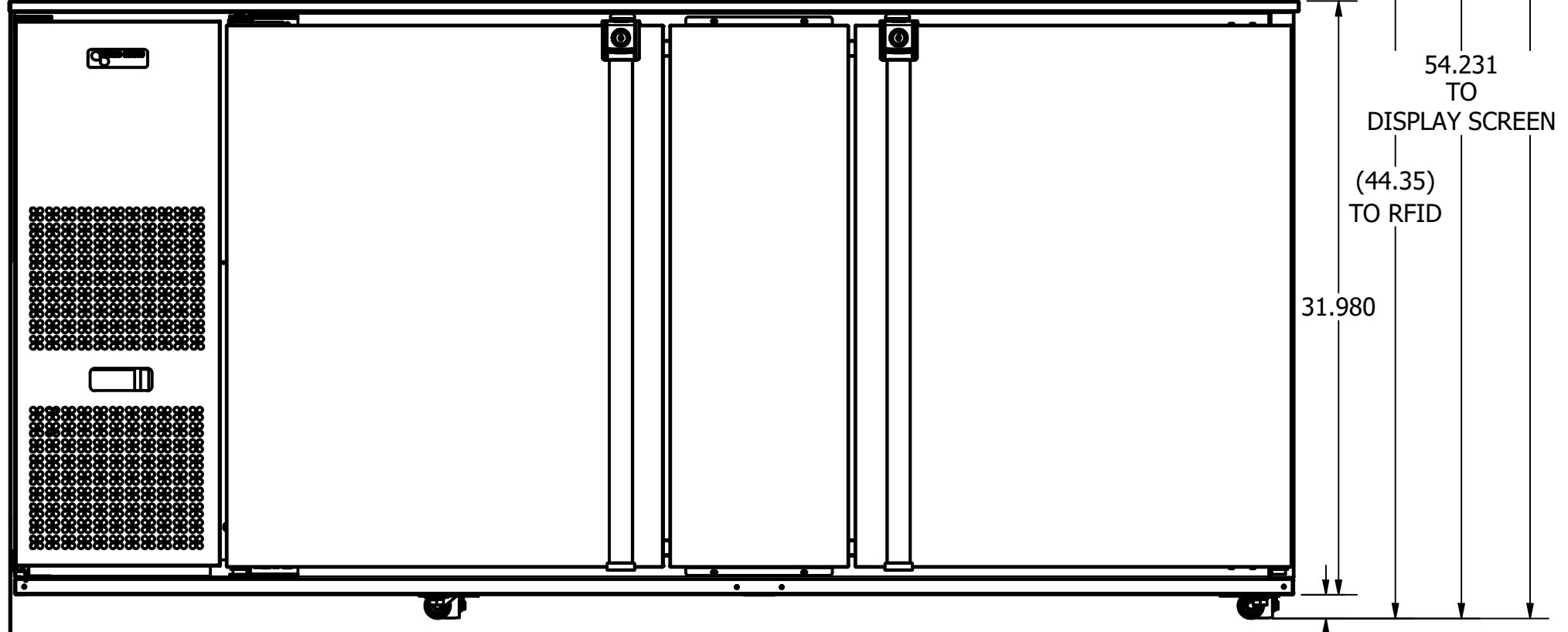
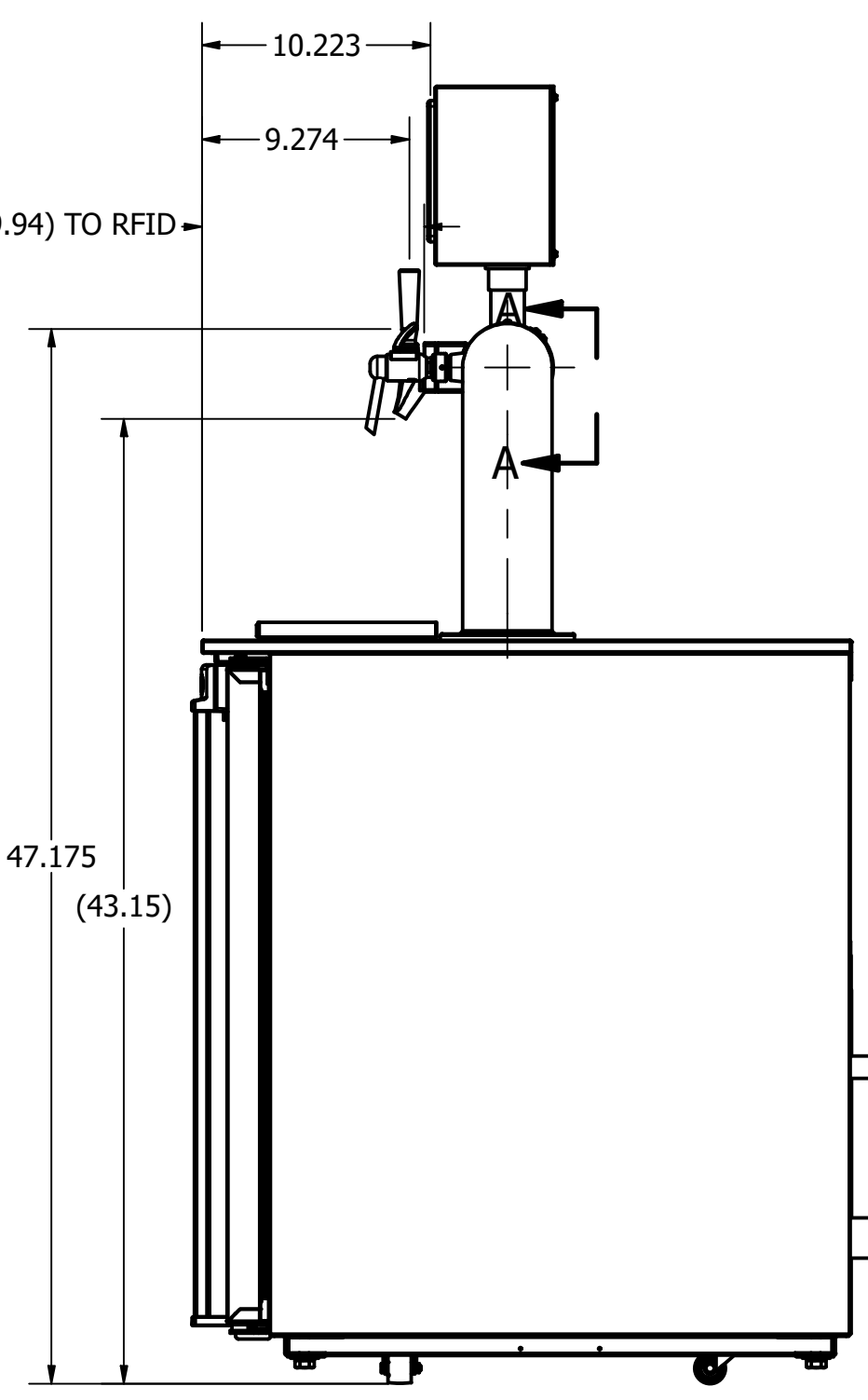

EIN/CRM	00	RELEASED	10/22/2021	NJS	
	REV	DESCRIPTION	DATE	ENG	APPD

GENERAL TOLERANCES UNLESS OTHERWISE SPECIFIED		MATERIAL		
DEC. PL	INCHES	MM	EST. WT.	
XX	±0.1	±2.5	N/A	
X.XX	±0.01	±0.25		
X.XXX	±0.005	±0.125		
SURFACE FINISH	✓	✓		
ANGLES ±1°		DESCRIPTION		SHEET 1 OF 2
BREAK ALL SHARP EDGES		PMB 6 PRODUCT ADA 68" DISPENSER		SCALE 1 : 8
				SIZE C
				ITEM NO./TYPE/REV.
				41157U01.dwg

MBB-68-E ADA
KEG FOOTPRINTS

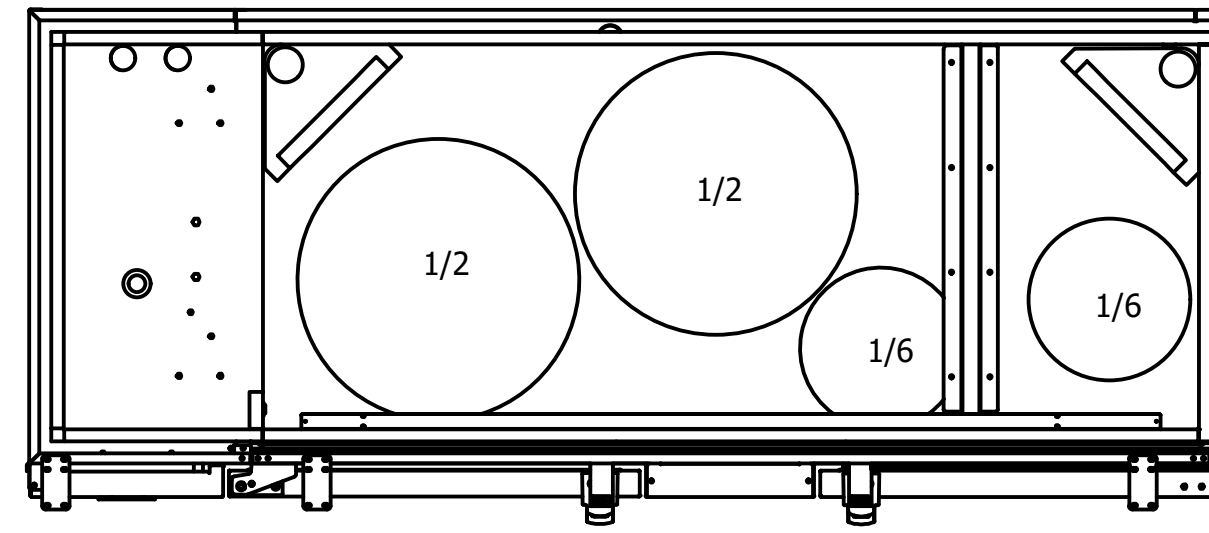
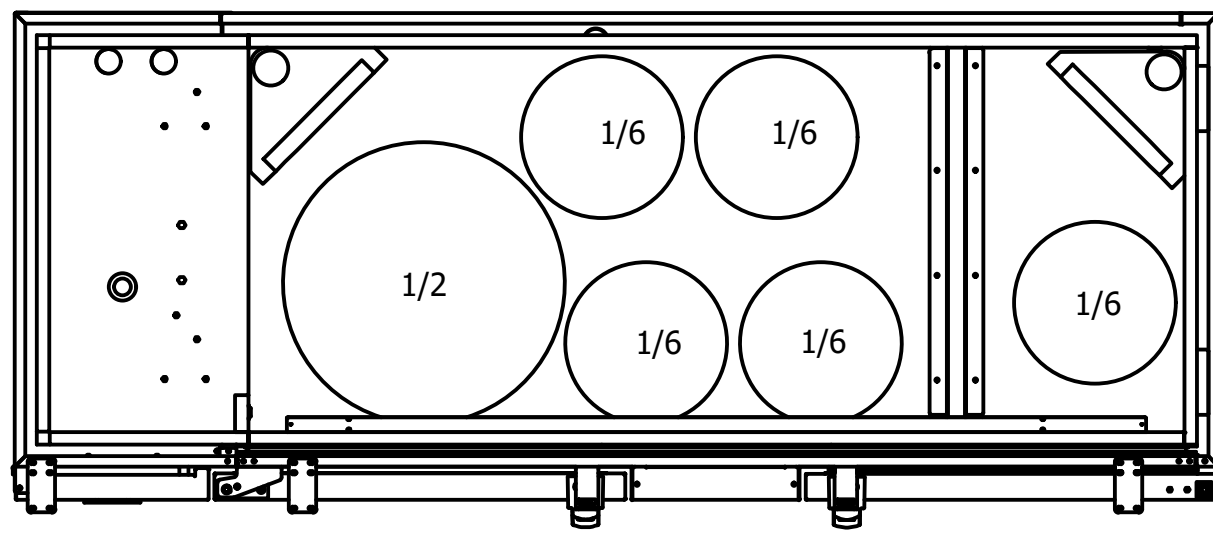
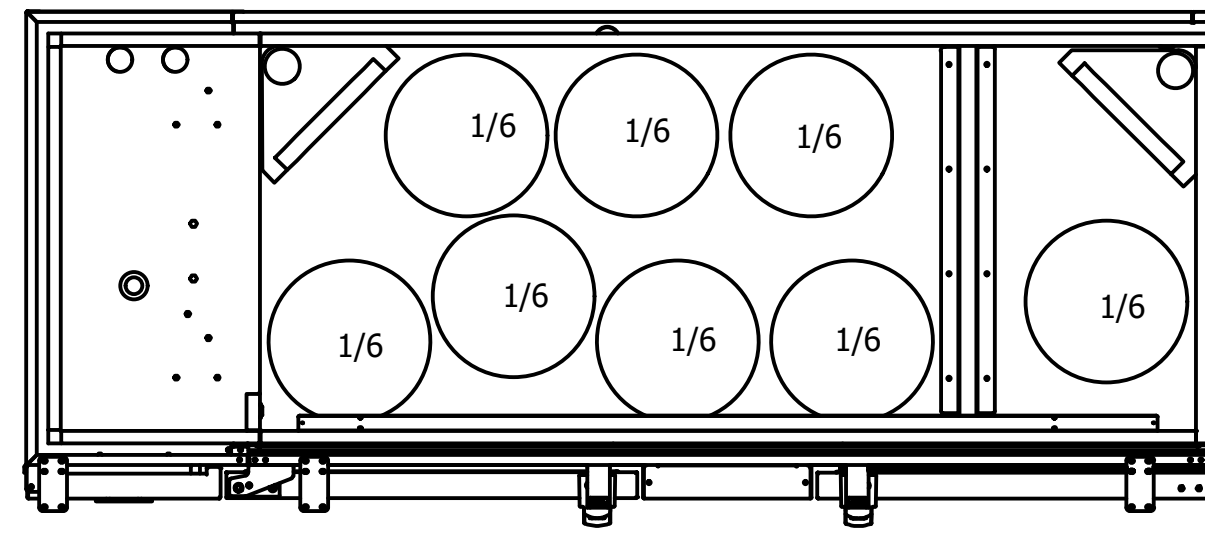
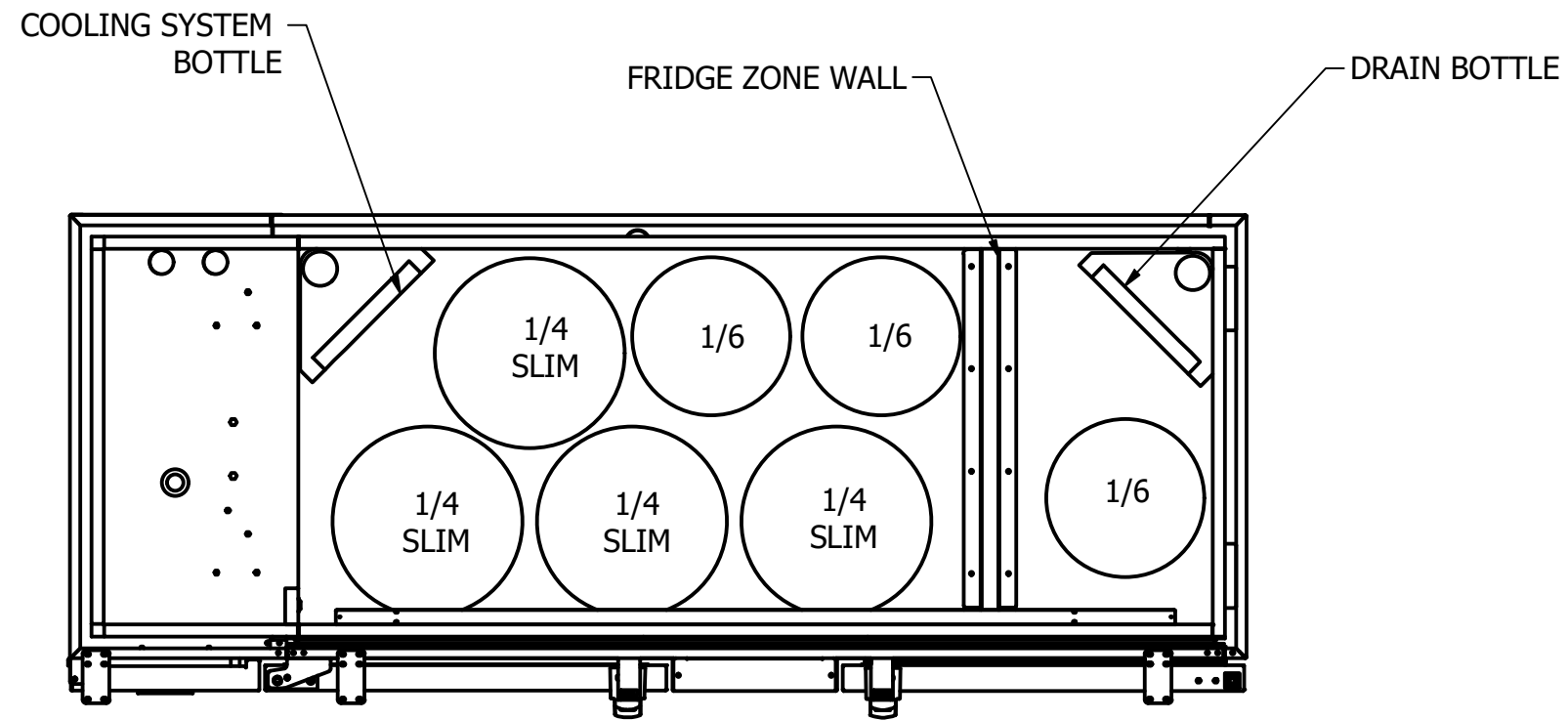
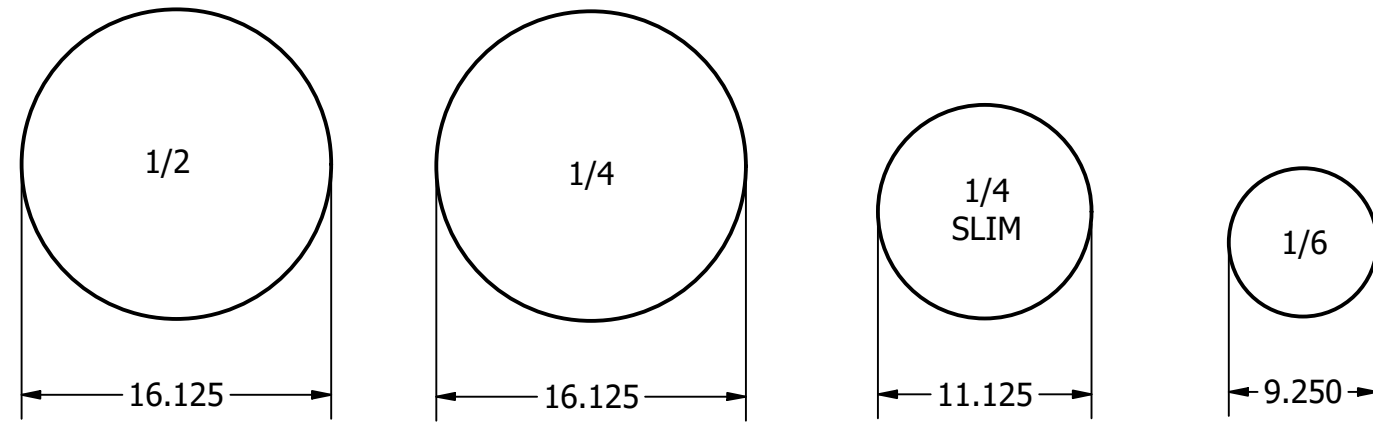

GENERAL TOLERANCES UNLESS OTHERWISE SPECIFIED DEC. PL. INCHES MM XX ±0.1 ±2.5 X.XX ±0.01 ±0.25 X.XXX ±0.005 ±0.125 SURFACE FINISH ANGES ±1° BREAK ALL SHARP EDGES		MATERIAL Generic SPECIFICATION EST. WT. N/A DESCRIPTION	
SHEET 2 OF 2 ITEM NO. /TYPE/REV.		SCALE 1 / 10 SIZE C	41157U01.dwg