

PARTS LIST

ITEM	QTY	PART NUMBER	DESCRIPTION
1	1	41146U01	PMB 8 PRODUCT 4" PASS THRU TOWER
2	1	41147	DRIP TRAY, PMB 8 PRODUCT TOWER
3	1	MBB 78 E ADA HC 115V	LOW PROFILE BACK BAR UNIT, 78", BLACK FINISH

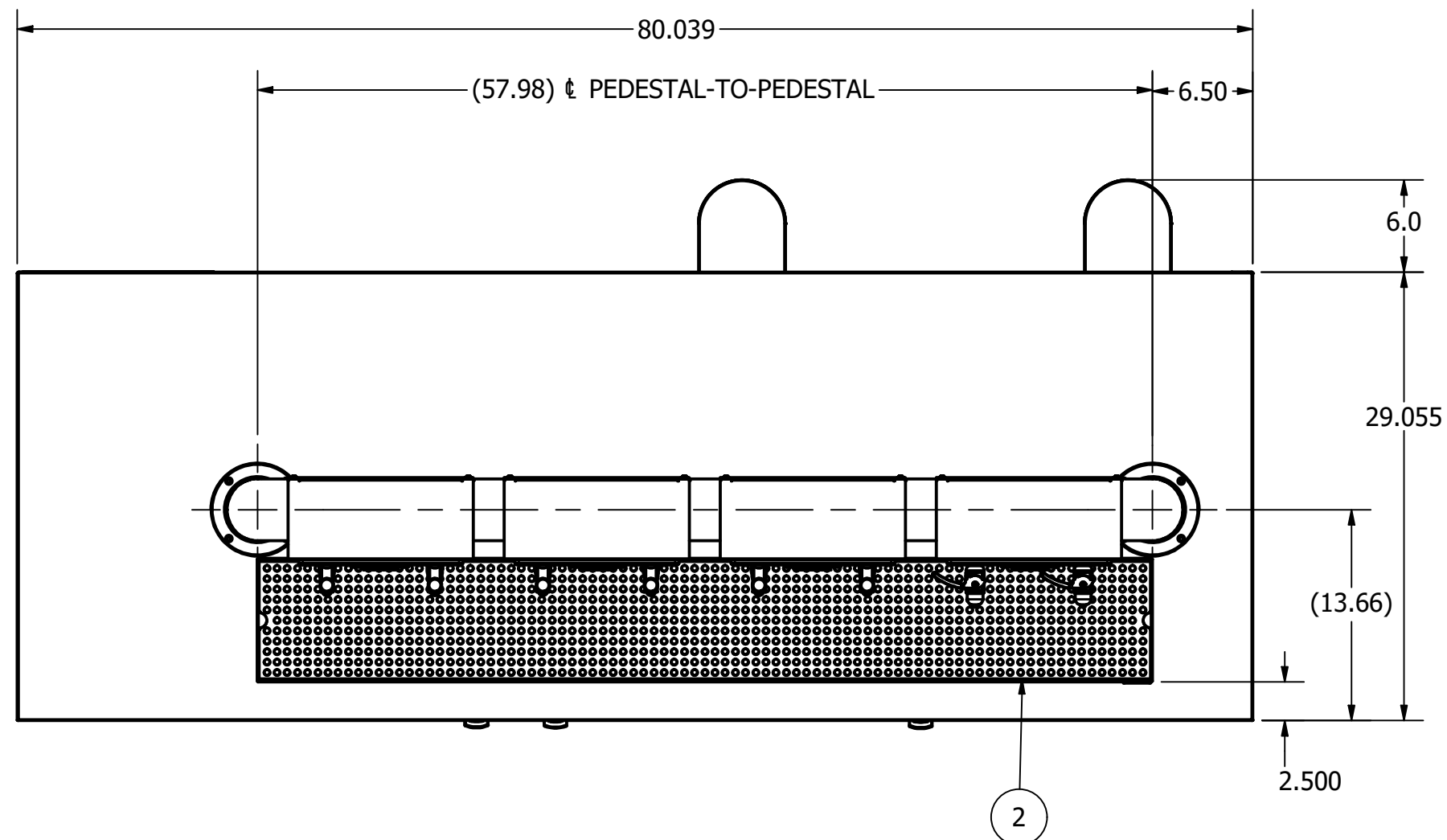

REMOVABLE BACK PANEL FOR FAUCET & LINE ACCESS

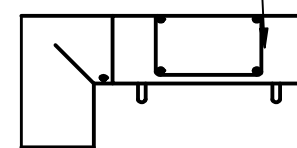

SECTION A-A

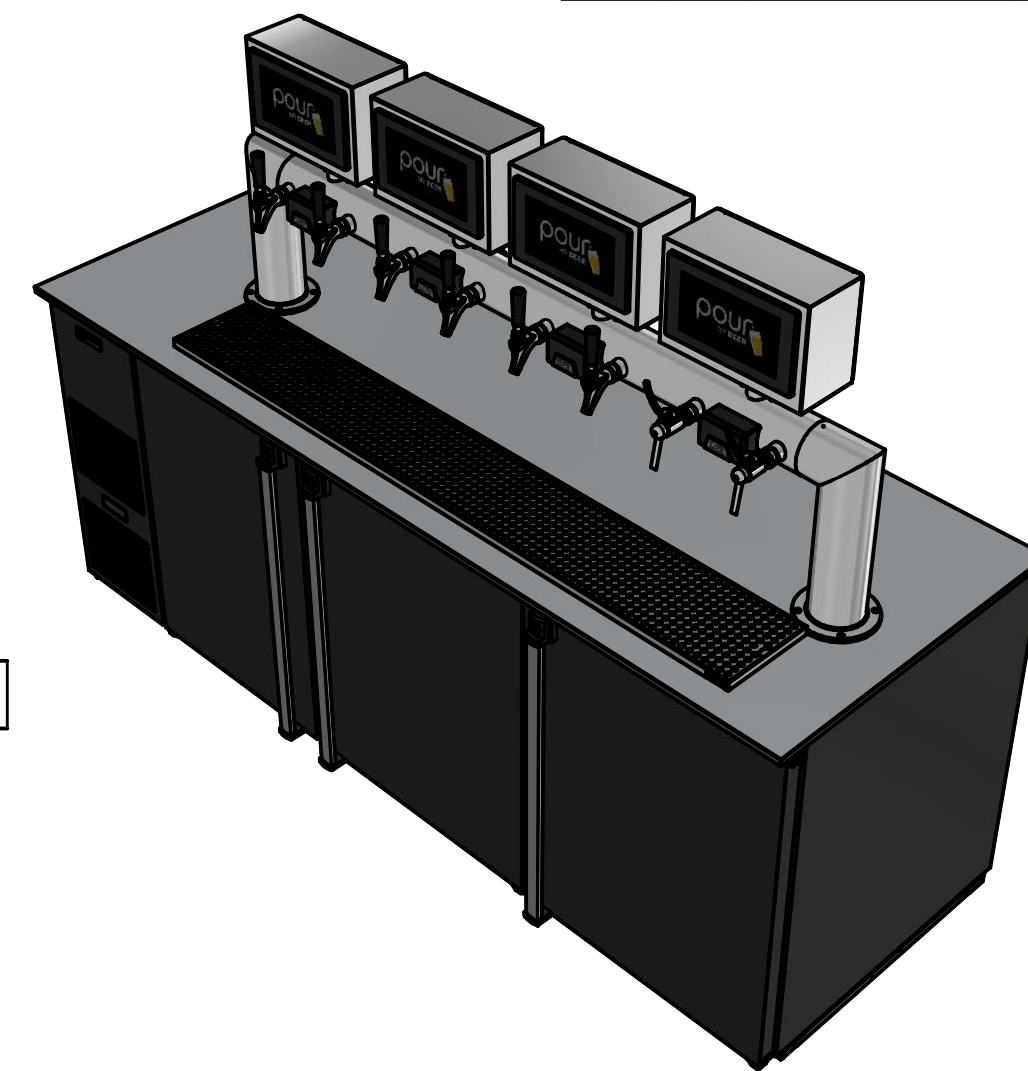

COMES WITH CO2 GAS REGULATOR AND 8 X "D" COUPLERS.
WHAT IS NOT PROVIDED: THE CO2 GAS AND THE ACTUAL BEER

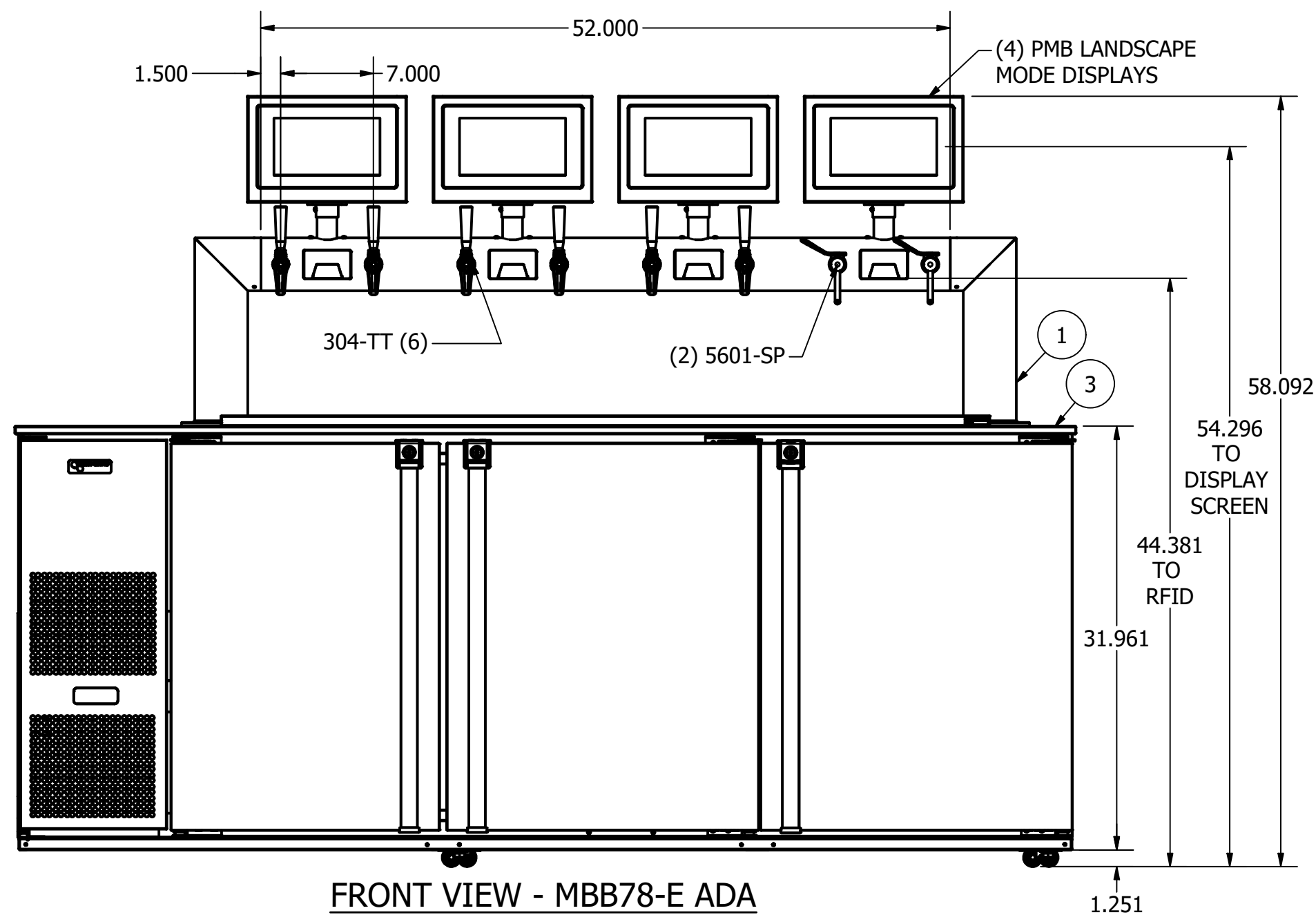

FRONT VIEW - MBB78-E ADA

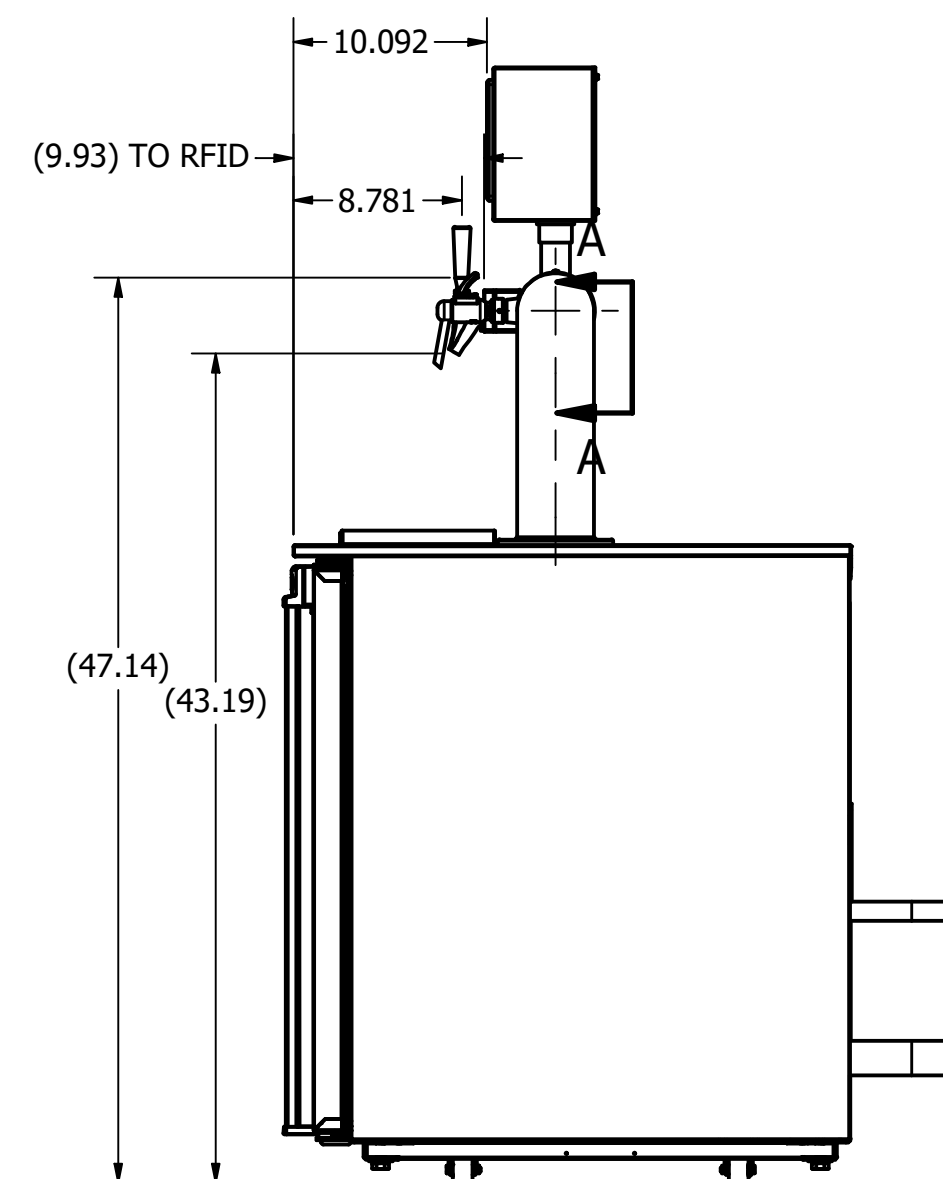

REQUIREMENTS

NETWORKING REQUIREMENTS:

1. HARD-LINE INTERNET CONNECTION TO THE POUR MY BEER SERVER COMPUTER. (x1).
2. HARD-LINE ETHERNET CONNECTION FROM THE POUR MY BEER SERVER COMPUTER TO THE MOBILE UNIT. (x1).
3. HARD-LINE ETHERNET CONNECTION FROM THE POUR MY BEER CHECK-IN TERMINAL(S) (x1 FOR EACH TERMINAL).

ALL LINES SHOULD BE TESTED AND TERMINATED BY THE CUSTOMER. THE POURMYBEER TERMINAL WILL SIT NEXT TO YOUR POS TERMINAL (THE POURMYBEER SYSTEM DOES NOT PROCESS PAYMENT). IF YOU WOULD LIKE MORE THAN ONE CHECK-IN AREA YOU WILL NEED ANOTHER LINE TO RUN TO THAT LOCATION.

GAS REQUIREMENTS: YOU WILL NEED TO PROVIDE YOUR OWN CO2 GAS TO CONNECT TO THE REGULATOR

SERVICE REQUIREMENTS: DRAFT TECH IS REQUIRED TO SERVICE AND CLEAN THE MOBILE UNIT ONCE A MONTH LIKE A REGULAR SYSTEM.

POWER REQUIREMENTS:

- 115V, 1 PHASE, 60 HZ
- FULL LOAD AMPS - 12.2 AMPS
- DEDICATED 15 AMP CIRCUIT

PLUG TYPE: NEMA-5-15P
CORD LENGTH: 8'

DRAIN:
DRAIN TO BOTTLE IN FRIDGE

GENERAL TOLERANCES UNLESS OTHERWISE SPECIFIED		MATERIAL		
DEC. PL	INCHES	MM	EST. WT.	
XX	±0.1	±2.5	N/A	
X.XX	±0.01	±0.25		
X.XXX	±0.005	±0.125		
SURFACE FINISH	✓	✓		
ANGLES ±1°				
BREAK ALL SHARP EDGES				
SPECIFICATION		DESCRIPTION		
		PMB 8 PRODUCT ADA 78" DISPENSER		
SHEET 1 OF 2		SCALE 1 : 10	SIZE C	
ITEM NO. /TYPE/REV.		41145U00.dwg		

00	RELEASED	06/15/2021	NJS	
REV	DESCRIPTION	DATE	ENG	APPD

MBB-78-E ADA
KEG FOOTPRINTS

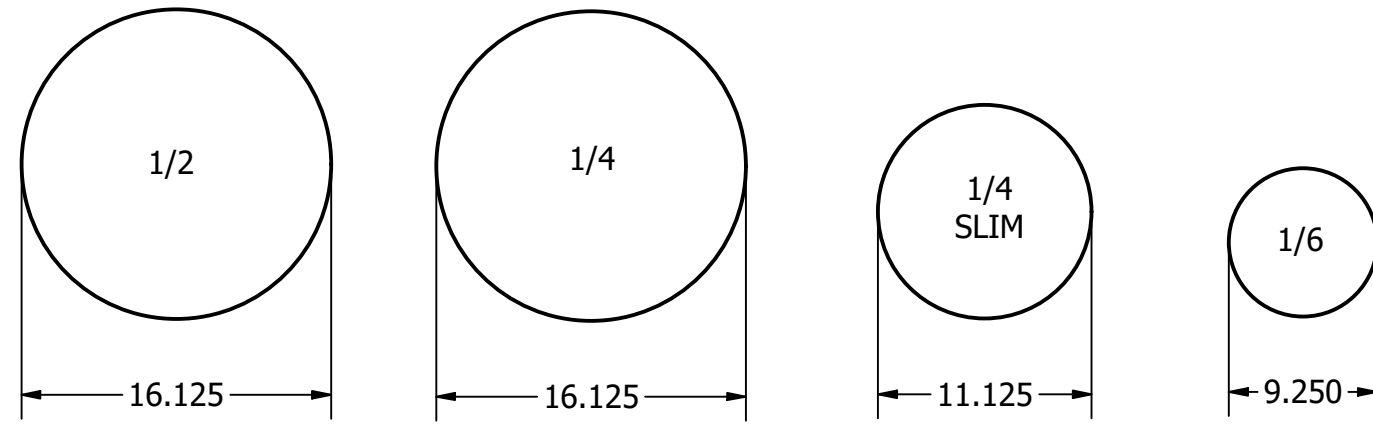

COOLING SYSTEM BOTTLE
FRIDGE ZONE WALL
DRAIN BOTTLE

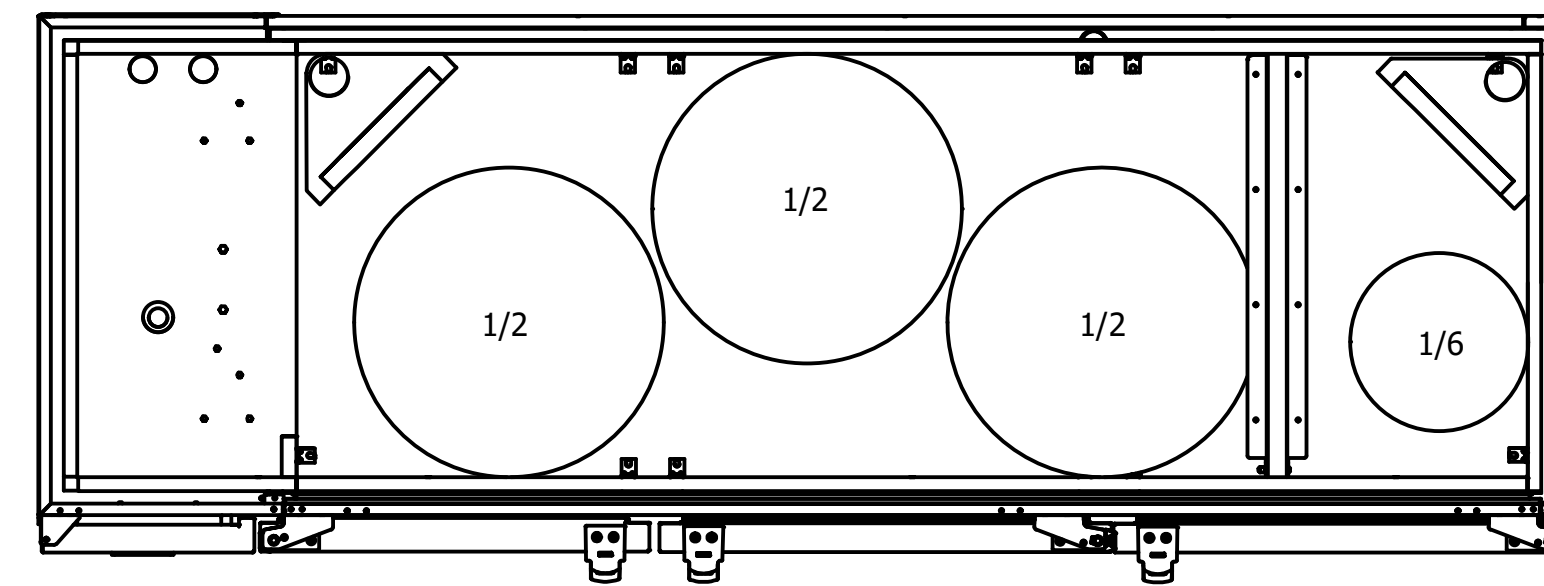
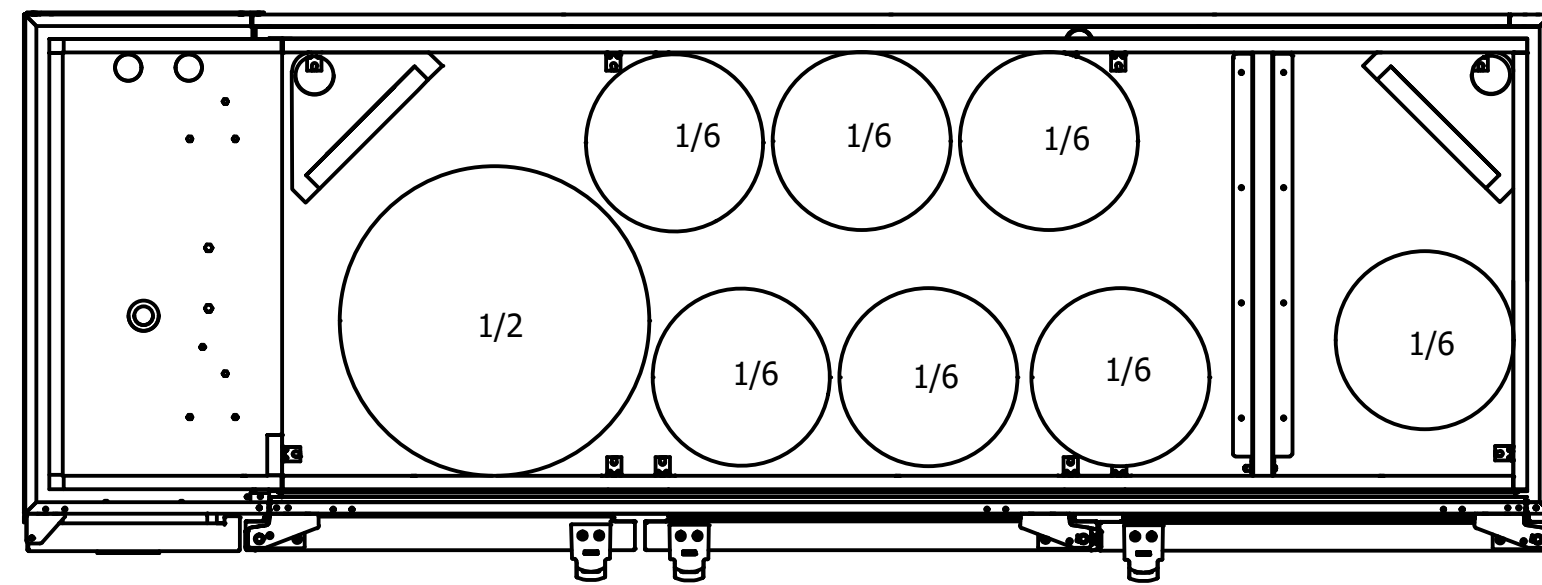
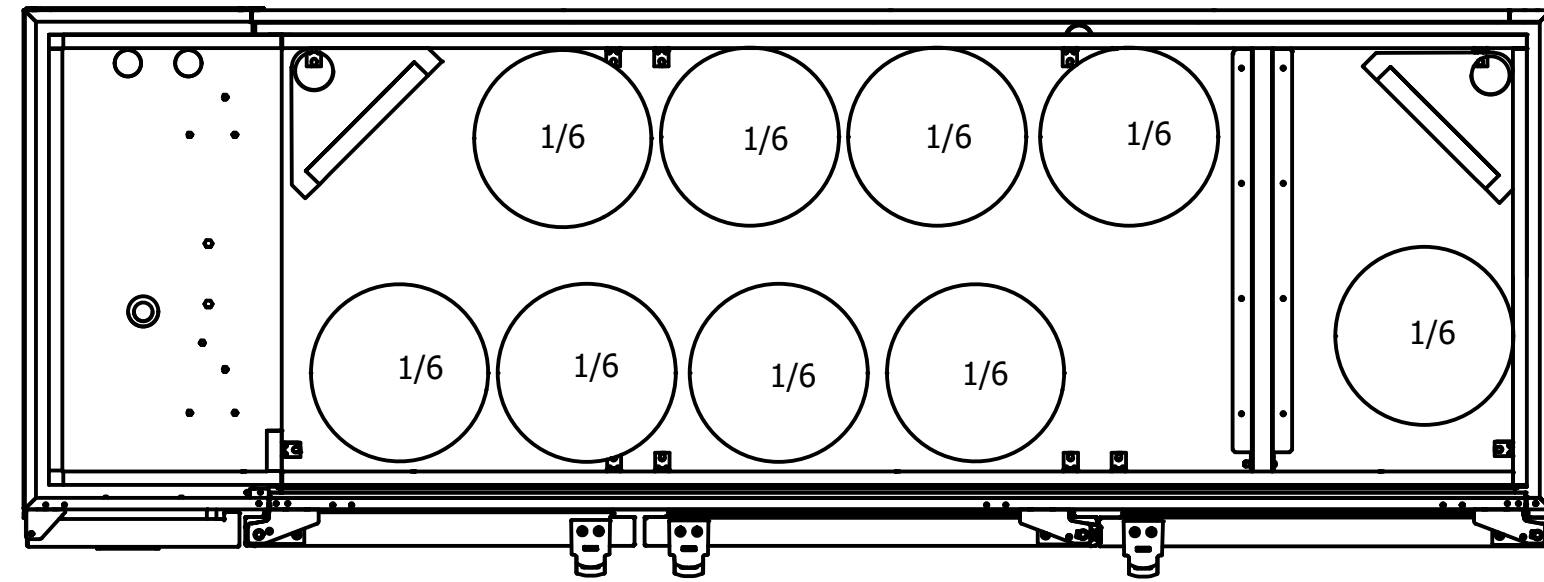
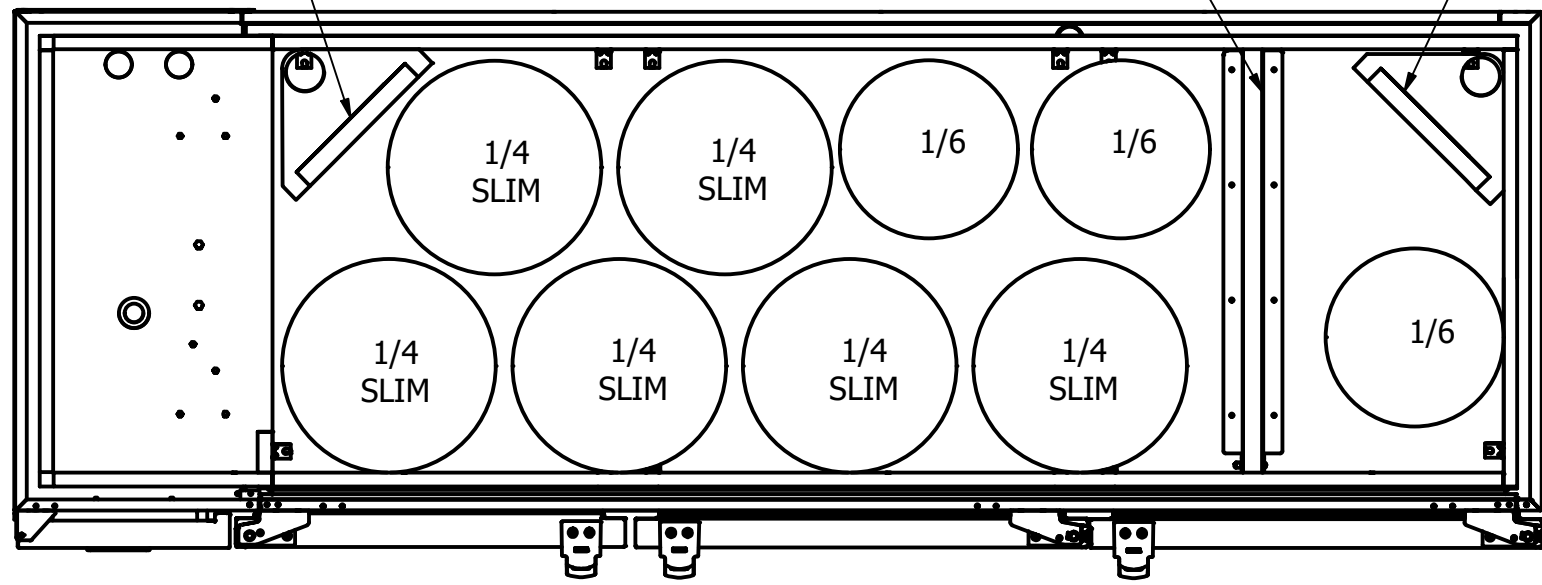

GENERAL TOLERANCES UNLESS OTHERWISE SPECIFIED DEC. PL. INCHES MM XX ±0.1 ±2.5 XXX ±0.01 ±0.25 XXXX ±0.005 ±0.125 SURFACE FINISH ANGES ±1° BREAK ALL SHARP EDGES		MATERIAL Generic SPECIFICATION EST. WT. N/A	
DESCRIPTION SHEET 2 OF 2 SCALE 1 / 10 SIZE C ITEM NO. /TYPE/REV. 41145U00.dwg			